



RoHS Compliant 100Gb/s CFP2 LR4 10km Optical Transceiver

OP-MCF2BxxL1SD-10



Product Features

- Supports up to 112Gbps bit rates
- Duplex LC connector
- Hot pluggable
- Operating electrical serial data rate up to 27.952493Gbps
- 4 parallel electrical serial interface
- Applicable for 10km SMF connection
- Low power consumption, < 6W
- Digital Diagnostic Monitor Interface
- MDIO Communication Interface
- Compliant with 100GBASE-LR4 and OTU4
- Operating case temperature:
Commerical:0 to 70 °C

Applications

- Local Area Network(LAN)
- Wide Area Network(WAN)
- Switch to router interface
- ITU-T OTU4 OTL4.4

Standards

- Compliant with IEEE 802.3ba
- Compliant with CFP2 MSA hardware specifications
- Compliant with CFP2 MSA management specifications
- Compliant with ITU-T G709/Y.1331
- Compliant with RoHS

Functional Description

OPTOSTAR' OP-MCF2BxxL1SD-10, 100G CFP2 LR4 optical transceiver integrates the transmit and receive path onto one module. On the transmit side, four lanes of serial data streams are recovered, retimed, and passed on to four laser drivers, which control four electric-absorption modulated lasers (EMLs) with 1296, 1300, 1305, and 1309 nm center wavelengths. The optical signals are then multiplexed into a single-mode fiber through an industry-standard LC connector. On the receive side, 4 lanes of optical data streams are optically demultiplexed by an integrated optical demultiplexer. Each data stream is recovered by a PIN photodetector and transimpedance amplifier, retimed, and passed on to an output driver. This module features a hot-pluggable electrical interface, low power consumption, and MDIO management interface.

Functional Diagram

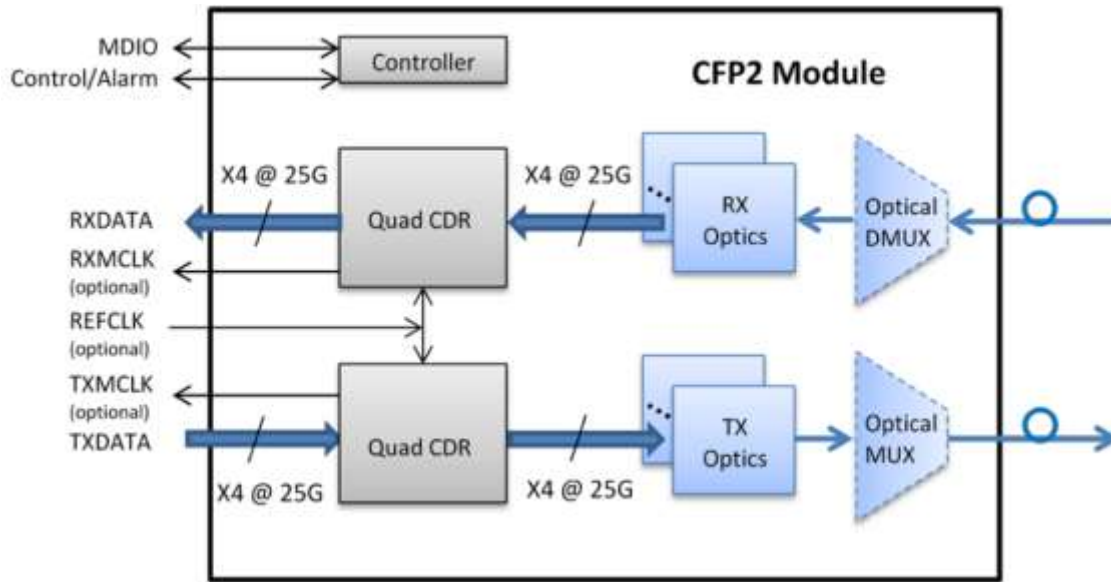

Absolute Maximum Ratings

Parameter	Symbol	Min.	Max.	Unit	Note
Supply Voltage	Vcc	-0.5	3.6	V	
Storage Temperature	Ts	-40	85	°C	
Relative Humidity	RH	0	85	%	

Note: Stress in excess of the maximum absolute ratings can cause permanent damage to the transceiver.

Recommended Operating Conditions

Parameter	Symbol	Min.	Typ	Max.	Unit	Note
Data Rate	DR		103.2	112	Gb/s	
Supply Voltage	Vcc	3.14	3.3	3.46	V	
Operating Case Temp.	Tc	0		70	°C	

Electrical Characteristics

(Tested under recommended operating conditions, unless otherwise noted)

Parameter	Symbol	Unit	Min	Typ	Max	Notes
Voltage Supply Electrical Characteristics						
Supply Current	Tx Section	Icc	A		1.88	1
	Rx Section					
Power Supply Noise		Vrip			2% DC	1MHz
					3% 1	10MHz
Total Dissipation Power	Pw	W			6	
Low Power Mode Dissipation	Plow	W			2	
Inrush Current	Class1	and	I-inrush	mA/usec	100	
Turn-off Current	Class2		I-turnoff	mA/usec	-100	
Inrush Current	Class3		I-inrush	mA/usec		200



Turn-off Current	Class4		I-turnoff	mA/usec	-200		
Different Signal Electrical Characteristics							
Single Ended Data Input Swing				mV	20		525
Single Ended Data Output Swing				mV	180		385
Differential Signal Output Resistance				Ω	80		120
Differential Signal Input Resistance				Ω	80		120
3.3V LVC MOS Electrical Characteristics							
Input High Voltage		3.3VIH		V	2.0		Vcc+0.3
Input Low Voltage		3.3VIL		V	-0.3		0.8
Input Leakage Current		3.3IIN		uA	-10		+10
Output High Voltage (IOH=100uA)		3.3VOH		V	Vcc-0.2		
Output Low Voltage (IOL=100uA)		3.3VOL		V			0.2
Minimum Pulse Width of Control Pin Signal		t_CNTL		us	100		
1.2V LVC MOS Electrical Characteristics							
Input High Voltage		1.2VIH		V	0.84		1.5
Input Low Voltage		1.2VIL V		0.3	1.2VIL V		0.36
Input Leakage Current		1.2IIN		uA	-100		+100
Output High Voltage		1.2VOH		V	1.0		1.5
Output Low Voltage		1.2VOL		V	-0.3		0.2
Output High Current		1.2IOH		mA			-4
Output Low Current		1.2IOL		mA	+4		
Input Capacitance		Ci		pF			10

High Speed Electrical Characteristics

Parameter	Symbol	Unit	Min.	Max.	Notes
Impedance	Zd	Ω	90	110	
Frequency		MHz	161.1328125		1/64 of electrical lane rate
Frequency Stability	Δ f	ppm	-100	100	For Ethernet
			-20	20	For Telecom
Differential Voltage	VDIFF	mV	400	900	Peak to Peak Differential
Common mode noise (rms)		mV		17.5	
RMS jitter		ps		10	Random Jitter Over frequency band of 10KHZ<f<10MHZ
Clock Duty Cycle		%	40	60	

Optical Characteristics

(Tested under recommended operating conditions, unless otherwise noted)

Parameter	Symbol	Unit	Min	Typ	Max	Notes
Optical Transmitter Characteristics						
Signaling rate, each lane		GBd	25.78125 ±100 ppm			100GBase-LR4



		27.9525 ±20 ppm			OTU4	
Four Lane Wavelength Range	λ1	nm	1294.53	1295.56	1296.59	
	λ2		1299.02	1300.05	1301.09	
	λ3		1303.54	1304.58	1305.63	
	λ4		1308.09	1309.14	1310.19	
Total launch power		dBm			10.5	100GBase-LR4
					10	OTU4
Average launch power, each lane	Pavg	dBm	-4.5		4.5	2
			-0.6		4	
Optical modulation amplitude, each lane (OMA) ²	OMA	dBm	-1.3		4.5	
Difference in launch power between any two lanes (OMA)		dB			5	
Extinction ratio	ER	dB	4			100GBase-LR4
			4		6.5	OTU4
Side-mode suppression ratio	SMSR	dB	30			
Transmitter and dispersion penalty, each lane	TDP	dB			2.2	
Optical return loss tolerance		dB			20	
Transmitter reflectance ³		dB			-12	
Transmitter eye mask {X1, X2, X3, Y1, Y2, Y3}			{0.25, 0.4, 0.45, 0.25, 0.28, 0.4}			100GBase-LR4
Optical Receiver Characteristics						
Receive Rate for Each Lane		Gbps		25.78125	27.9525	
Overload Input Optical Power	Pmax	dBm	5.5			3
Average Receive Power for Each Lane	Pin	dBm	-8.6		3	4
Receive Power In OMA for Each Lane	PinOMA	dBm			3	
Difference in Receive Power in OMA between Any Two Lanes		dBm				
Receiver Sensitivity in OMA for Each Lane	SOMA	dBm			-8.6	5
Stressed Receiver Sensitivity in OMA for Each Lane		dBm			-6.8	6, 7

Notes:

1. The supply current includes CFP2 module’s supply current and test board workingcurrent.
2. Average launch power, each lane (min) is informative for 100GBase-LR4, not the principal indicator of signal strength.
3. The receiver shall be able to tolerate , without damage, continuous exposure to an optical input signal having this average power level
4. Average receive power, each lane (min) is informative and not the principal indicator of signal strength. A received power below this value cannot be compliant; however, a value above this does not ensure compliance
5. Receiver sensitivity (OMA), each lane (max) is informative
6. Measured with conformance test signal at TP3 for BER=10⁻¹²
7. conditions of stressed receiver sensitivity test: vertical eye closure penalty for each lane is 1.8dB;stressed eye J2 jitter for each lane is 0.3UI; stressed eye J9 jitter for each lane is 0.47UI.

Pin Description

The CFP2 connector has 104 pins which are arranged in Top and Bottom rows. The pin map is shown in Table below:

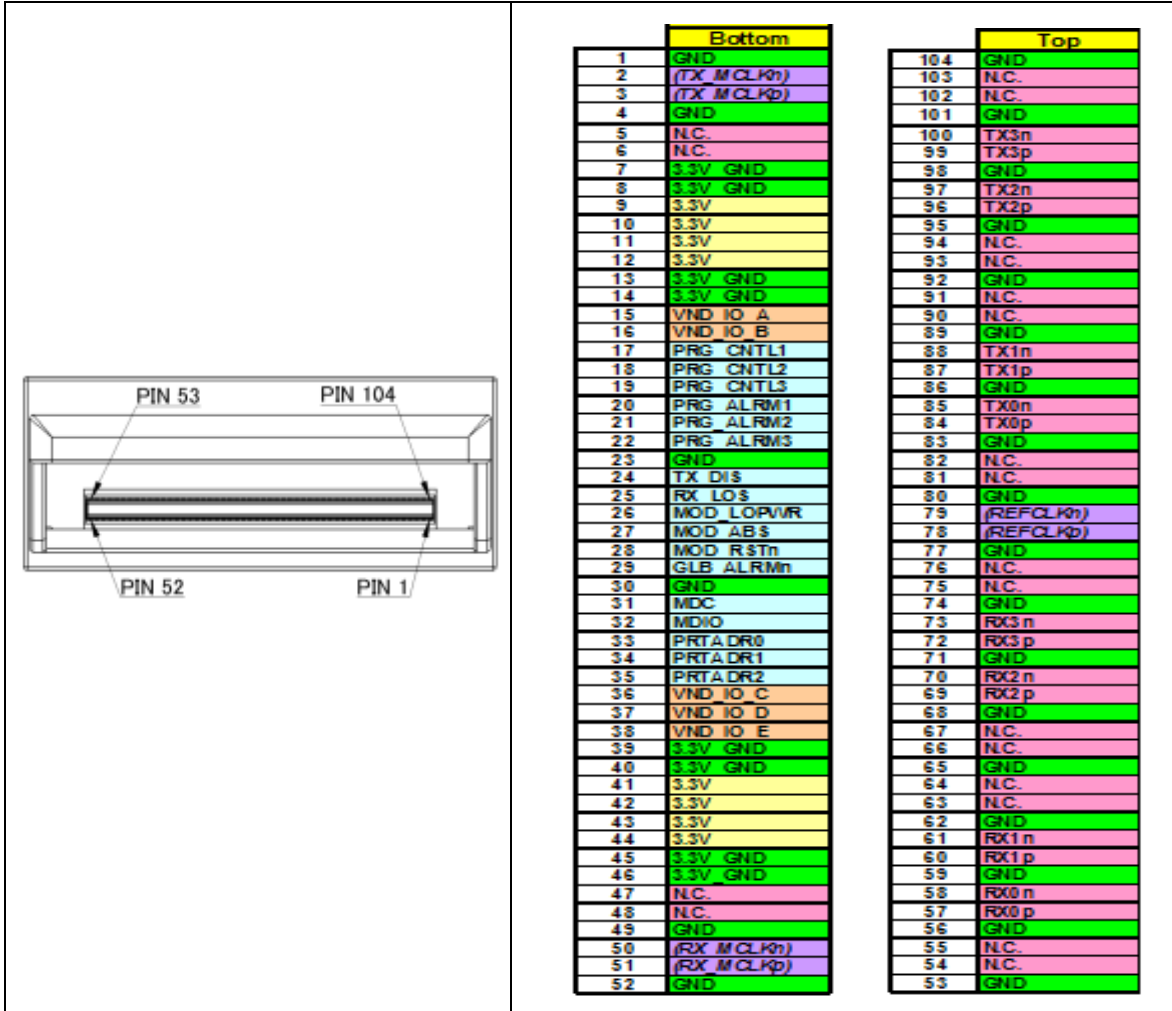

Pin	Name	I/O	Logic	Description
1	GND			
2	(TX_MCLKn)	O	CML	For optical waveform testing. Not for normal use.
3	(TX_MCLKp)	O	CML	For optical waveform testing. Not for normal use.
4	GND			
5	N.C			No Connect
6	N.C			
7	3.3V_GND			3.3V Module Supply Voltage Return Ground, can be separate or tied together with Signal Ground
8	3.3V_GND			
9	3.3V			3.3V Module Supply Voltage
10	3.3V			
11	3.3V			
12	3.3V			
13	3.3V_GND			3.3V Module Supply Voltage Return Ground, can be separate or tied together with Signal Ground
14	3.3V_GND			
15	VND_IO_A	I/O		Module Vendor I/O A. Do Not Connect!
16	VND_IO_B	I/O		Module Vendor I/O A. Do Not Connect!



17	PRG_CNTL1	I	LVC MOS w/ PUR	Programmable Control 1 set over MDIO, MSA Default: TRXIC_RSTn, TX & RX ICs reset, "0": reset, "1" or NC: enabled = not used
18	PRG_CNTL2	I	LVC MOS w/ PUR	Programmable Control 2 set over MDIO, MSA Default: Hardware Interlock LSB, "00": ≤3W, "01": ≤6W, "10": ≤9W, "11" or NC: ≤12W = not used
19	PRG_CNTL3	I	LVC MOS w/ PUR	Programmable Control 2 set over MDIO, MSA Default: Hardware Interlock LSB, "00": ≤3W, "01": ≤6W, "10": ≤9W, "11" or NC: ≤12W = not used
20	PRG_ALARM1	O	LVC MOS	Programmable Alarm 1 set over MDIO, MSA Default: HIPWR_ON, "1": module power up completed, "0": module not high powered up
21	PRG_ALARM2	O	LVC MOS	Programmable Alarm 2 set over MDIO, MSA Default: MOD_READY, "1": Ready, "0": not Ready.
22	PRG_ALARM3	O	LVC MOS	Programmable Alarm 3 set over MDIO, MSA Default: MOD_FAULT, fault detected, "1": Fault, "0": No Fault
23	GND			
24	TX_DIS	I	LVC MOS w/ PUR	Transmitter Disable for all lanes, "1" or NC = transmitter disabled, "0" = transmitter enabled
25	RX_LOS	O	LVC MOS	Receiver Loss of Optical Signal, "1": low optical signal, "0": normal condition
26	MOD_LOPWR	I	LVC MOS w/ PUR	Module Low Power Mode. "1" or NC: module in low power (safe) mode, "0": power-on enabled
27	MOD_ABS	O	GND	Module Absent. "1" or NC: module absent, "0": module present, Pull Up Resistor on Host
28	MOD_RSTn	I	LVC MOS w/ PDR	Module Reset. "0" resets the module, "1" or NC = module enabled, Pull Down Resistor in Module
29	GLB_ALRMn	O	LVC MOS	Global Alarm. "0": alarm condition in any MDIO Alarm register, "1": no alarm condition, Open Drain, Pull Up Resistor on Host
30	GND			
31	MDC	I	1.2VCMOS	Management Data Clock (electrical specs as per IEEE Std 802.3ae-2008 and ba-2010)
32	MDIO	I/O	1.2VCMOS	Management Data I/O bi-directional data (electrical specs as per IEEE Std 802.3ae-2008 and ba-2010)
33	PRTADR0	I	1.2VCMOS	MDIO Physical Port address bit 0
34	PRTADR1	I	1.2VCMOS	MDIO Physical Port address bit 1
35	PRTADR2	I	1.2VCMOS	MDIO Physical Port address bit 2
36	VND_IO_C	I/O		Module Vendor I/O C. Do Not Connect!
37	VND_IO_D	I/O		Module Vendor I/O D. Do Not Connect!
38	VND_IO_E	I/O		Module Vendor I/O E. Do Not Connect!
39	3.3V_GND			
40	3.3V_GND			
41	3.3V			3.3V Module Supply Voltage
42	3.3V			
43	3.3V			
44	3.3V			
45	3.3V_GND			
46	3.3V_GND			
47	N.C			No Connect
48	N.C			
49	GND			
50	(RX_MCLKn)	O	CML	For optical waveform testing. Not for normal use.
51	(RX_MCLKp)	O	CML	



52	GND			
53	GND			
54	N.C.			
55	N.C.			
56	GND			
57	RX0p			25 Gbps receiver data; Lane 0
58	RX0n			25 Gbps receiver data bar; Lane 0
59	GND			
60	RX1p			25 Gbps receiver data; Lane 1
61	RX1n			25 Gbps receiver data bar; Lane 1
62	GND			
63	N.C.			
64	N.C.			
65	GND			
66	N.C.			
67	N.C.			
68	GND			
69	RX2p			25 Gbps receiver data; Lane 2
70	RX2n			25 Gbps receiver data bar; Lane 2
71	GND			
72	RX3p			25 Gbps receiver data; Lane 3
73	RX3n			25 Gbps receiver data bar; Lane 3
74	GND			
75	N.C.			
76	N.C.			
77	GND			
78	(REFCLKp)	CML		Module reference clock. No connect.
79	(REFCLKn)	CML		Module reference clock. No connect.
80	GND			
81	N.C.			
82	N.C.			
83	GND			
84	TX0p			25 Gbps transmitter data; Lane 0
85	TX0n			25 Gbps transmitter data bar; Lane 0
86	GND			
87	TX1p			25 Gbps transmitter data; Lane 1
88	TX1n			25 Gbps transmitter data bar; Lane 1
89	GND			
90	N.C.			
91	N.C.			
92	GND			
93	N.C.			
94	N.C.			
95	GND			



96	TX2p			25 Gbps transmitter data; Lane 2
97	TX2n			25 Gbps transmitter data bar; Lane 2
98	GND			
99	TX3p			25 Gbps transmitter data; Lane 3
100	TX3n			25 Gbps transmitter data bar; Lane 3
101	GND			
102	N.C.			
103	N.C.			
104	GND			

Hardware Control Pins

The CFP2 Module support real-time control functions via hardware pins, listed in the following

Pin	Symbol	Description	I/O	Logic	H	L	Pull-up/down
17	PRG_CNTL1	Programmable Control 1 MSA Default: TRXIC_RSTn, TX&RX ICs reset, "0":reset,"1"	I	3.3V LVC MOS	per CFP MSA Management Interface Specification		Pull-Up Note1
18	PRG_CNTL2	Programmable Control 2 MSA Default :Hardware Interlock LSB	I	3.3V LVC MOS			Pull-Up Note1
19	PRG_CNTL3	Programmable Control 3 MSA Default:Hardware Interlock MSB	I	3.3V LVC MOS			Pull-Up Note1
26	MOD_LOPWR	Module Low Power Mode	I	3.3V LVC MOS Low Power Enable Pull-Up	Low Power	Enable	Pull-Up Note1
28	MOD_RSTn	Module Reset(Invert)	I	3.3V LVC MOS	Enable	Reset	Pull-Down Note2

Notes:

1. Pull-Up resistor (4.7KOhm to 10 KOhm) is located within the CFP2 module
2. Pull-Down resistor (4.7KOhm to 10 kOhm) is located within the CFP2 module

Hardware Alarm Pins

The CFP2 Module supports alarm hardware pins listed in the following

Pin	Symbol	Description	I/O	Logic	H	L	Pull-up/down
20	PRG_ALR M1	Programmable Alarm 1 MSA Default:HIPWR_ON	O	3.3V LVC MOS	Active High per MDIO document		
21	PRG_ALR M2	Programmable Alarm 2 MSA default:MOD_READY, Ready State has been reached	O	3.3V LVC MOS			
22	PRG_ALR M3	Programmable Alarm 3 MSA Default: MOD_FAULT	O	3.3V LVC MOS			
27	MOD_ABS	Module Absent	O	3.3V LVC MOS	Absent	Present	Pull-Down Note1
25	RX_LOS	Receiver Loss of Signa	O	3.3V LVC MOS	Loss of Signal	OK	

Note:

- 1.:Pull-Down resistor (<100Ohm) is located within the CFP2 module. Pull-up should be located on the host

Management Interface Pins(MDIO)

The CFP2 Module supports alarm, control and monitor functions via an MDIO bus. The CFP2 MDIO pins are listed in the following:

Pin No.	Symbol	Description	I/O	Logic	H	L	Pull-up/down
29	GLB-ALRMn	Global Alarm	I	3.3V LVCMOS	OK	Alarm	
32	MDIO	Management interface bidirectional data	I/O	1.2V LVCMOS			
31	MDC	Management interface clock input	I	1.2V LVCMOS			
33	PRTADR0	MDIO physical port address bit 0	I	1.2V LVCMOS	Per MDIO		
34	PRTADR1	MDIO physical port address bit 1	I	1.2V LVCMOS			
35	PRTADR2	MDIO physical port address bit 2	I	1.2V LVCMOS			

Hardware Signaling Pin Timing Requirements

Timing Parameters for CFP2 hardware Signal Pins are listed in the following:

Parameter	Symbol	Unit	Min.	Max.	Notes
Hardware MOD_LOPWR assert	t_MOD_LOPWR_assert	ms		1	
Hardware MOD_LOPWR deassert	t_MOD_LOPWR_deassert	s		60	Stored in NVR register 8072h
Management interface clock period	t_prd	ns	250		MDC is 4 MHz rate or less
Host MDIO setup time	t_setup	ns	10		
Host MDIO hold time	t_hold	ns	10		
CFP2 MDIO delay time	t_delay	ns	0	175	
GLB_ALARM assert time	GLB_ALRMn_assert	ms		150	A logic "OR" of associated MDIO alarm and status registers
GLB_ALARM deassert time	GLB_ALRMn_deassert	ms		150	A logic "OR" of associated MDIO alarm and status registers
Minimum pulse width of control pin signal	t_CNTL	µs	100		
Initialization time from reset	t_initialize	s		2.5	
TX_Disable assert time	t_deassert	µs		100	Transmitter disable, application specific
TX_Disable deassert time1	t_assert	ms		5	Time from Tx Disable pin deasserted until CFP2 module enters the Tx-turn-on state Stored in NVR register 8073h
RX_LOS assert time	t_loss_assert	µs		100	From occurrence of loss of signal to assertion of RX_LOS
RX_LOS deassert time	t_loss_deassert	µs		100	From occurrence of return of signal to deassert of RX_LOS

CFP2 Lane Assignment

Lane	Center Frequency	Center Wavelength	Wavelength Range
L0	231.4 THz	1295.56 nm	1294.53 to 1296.59 nm
L1	230.6 THz	1300.05 nm	1299.02 to 1301.09 nm
L2	229.8 THz	1304.58 nm	1303.54 to 1305.63 nm
L3	229.0 THz	1309.14 nm	1308.09 to 1310.19 nm

Package Dimensions

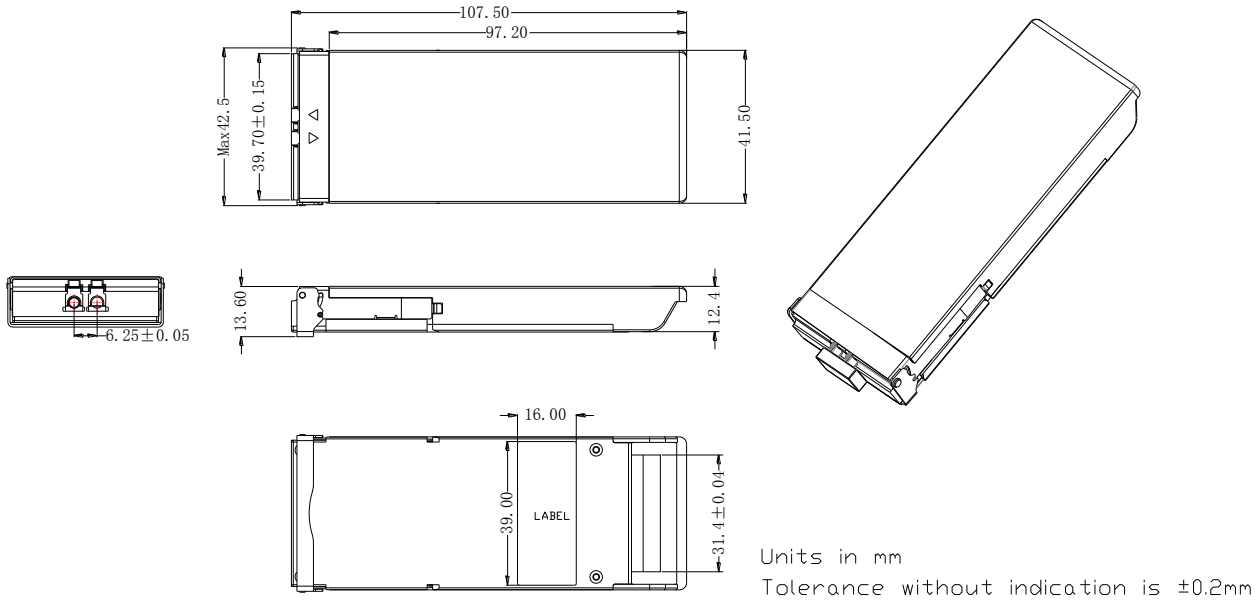

Ordering Information

Part Number	Description
OP-MCF2BxxL1SD-10	CFP2 100G LR4 10Km 0~70°C

Important Notice

Performance figures, data and any illustrative material provided in this data sheet are typical and must be specifically confirmed in writing by OPTOSTAR before they become applicable to any particular order or contract. In accordance with the OPTOSTAR policy of continuous improvement specifications may change without notice.

The publication of information in this data sheet does not imply freedom from patent or other protective rights of OPTOSTAR or others. Further details are available from any OPTOSTAR sales representative.



Contact OPTOSTAR

Shenzhen Optostar Optoelectronics Co., Ltd

Address:A-14,Haide Building,the Intersection of Nanxin Road and Haide Second Road Nanshan District
Shenzhen,China .

Tel: +86-755-26400198 +86-755-26400288 Fax: +86-755-26411001

Email: info@optostar.com.cn

Skype:ouyangroya

Web: www.optostar.com.cn